

Integrated Professional Cleaning



**IPC** Portotecnica

## **Service Manual**

Rev.1.0 January 2014

# **OPTIMA DS**

**145M - 175T - 195T**

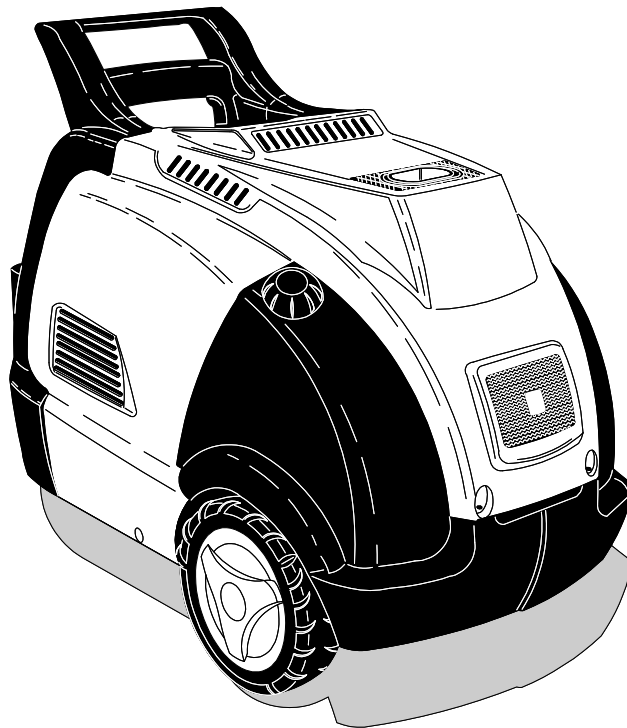

## Service Manual

Ip Cleaning S.p.A.  
Viale Treviso, 63 – 30026 Summaga di Portogruaro – VENICE – ITALY  
Tel. +39 0421 205511 (r.a.) – Fax +39 0421 204227  
Internet address: [www.ipcportotecnica.com](http://www.ipcportotecnica.com)  
e-mail address: [infoipcportotecnica@ipcleaning.com](mailto:infoipcportotecnica@ipcleaning.com)

## INDEX

<b>1. The machine doesn't starts</b>	<b>Pag.</b>
<b><u>1a</u></b> No electrical connection	4
<b><u>1b</u></b> Electric motor's overload relay tripping or burnt fuses	4
<b><u>1c</u></b> Low voltage transformer burnt	11
<b><u>1d</u></b> Contactor not working	11
<b>2. No water jet at the lance nozzle</b>	<b>Pag.</b>
<b><u>2a</u></b> Bad or missing water feeding connection	14
<b><u>2b</u></b> Inlet water filter clogged	14
<b><u>2c</u></b> Air intake from the water feeding circuit	15
<b><u>2d</u></b> Pump head's valves stuck	15
<b><u>2e</u></b> Air intake from the detergent circuit	17
<b><u>2f</u></b> High pressure nozzle clogged	18
<b>3. No pressure to the lance</b>	<b>Pag.</b>
<b><u>3a</u></b> Defective water feeding connection	19
<b><u>3b</u></b> Inlet water filter clogged	19
<b><u>3c</u></b> Air intake from the water feeding circuit	19
<b><u>3d</u></b> Pump head's valves stuck or worn	19
<b><u>3e</u></b> Air intake from the detergent circuit	20
<b><u>3f</u></b> High pressure nozzle worn or deformed	20
<b><u>3g</u></b> Pressure adjusting valve setting at minimum position	21
<b><u>3h</u></b> Seat of pressure adjusting valve damaged	21
<b><u>3i</u></b> Pump gaskets worn or water leaks from the pump's head	24

<b>4. The boiler doesn't ignite</b>	<b>Pag.</b>
<u>4a</u> Wrong blower's motor rotation sense (only for Three-phase models)	27
<u>4b</u> Missing fuel	27
<u>4c</u> Suction pipe and/or, fuel filters clogged	27
<u>4d</u> Fuel pump out of order	28
<u>4e</u> Fuel solenoid not electrically supplied or defective or damaged	30
<u>4f</u> Fuel nozzle clogged or spraying irregularly	30
<u>4g</u> High voltage ignition transformer not functioning	31
<u>4h</u> Sparking plugs are dirt or worn	31
<b>5. Bad fuel combustion</b>	<b>Pag.</b>
<u>5a</u> Fuel tank almost empty	32
<u>5b</u> Suction pipe and/or, fuel filters clogged	32
<u>5c</u> Fuel pump pressure setting not properly adjusted	32
<u>5d</u> Fuel with impurities, dirt or water	32
<u>5e</u> Combustion adjustment incorrect	32
<u>5f</u> Burner's coil clogged by dirt or soot	34
<u>5g</u> Fuel nozzle partially clogged	35
<b>6. Poor hot water temperature at the machine outlet</b>	<b>Pag.</b>
<u>6a</u> Thermostat adjusted at minimum or not working	36
<u>6b</u> Fuel filters clogged or dirty	36
<u>6c</u> Fuel pump pressure setting not properly adjusted	36
<u>6d</u> Fuel with impurities, dirt or water	36
<u>6e</u> Fuel nozzle partially clogged	36
<u>6f</u> Burner's coil pipe internally clogged by limestone	36
<b>7. Poor detergent delivery</b>	<b>Pag.</b>
<u>7a</u> Detergent's tap closed or clogged	37
<u>7b</u> Empty detergent tank	37
<u>7c</u> The check valve of the detergent circuit is stuck or clogged	37
<u>7d</u> Burner's coil or high pressure outlet pipes clogged	37
<b>8. Oil and water emulsion phenomena to the high pressure pump oil</b>	<b>Pag.</b>
<u>8a</u> Extremely high environment humidity percentage	38
<u>8b</u> High pressure pump gaskets worn	38
<u>8c</u> High pressure pump pistons damaged	39

## 1. The machine doesn't start

- 1) **TROUBLE:** Rotating the main switch "0 - I" (A) the high pressure cleaner doesn't start or suddenly stops after a while.

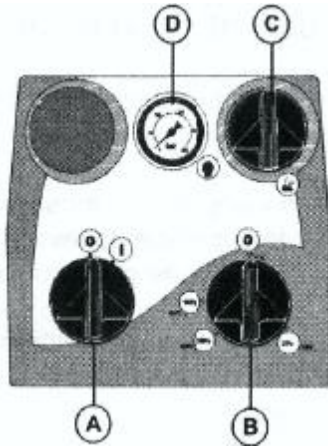

fig. 1

- CAUSES:**
- 1a** No electrical connection
  - 1b** Electric motor's overload relay tripping or burnt fuses
  - 1c** Low voltage transformer burnt
  - 1d** Contactor not working

### **REMEDIES:**

**1a** Check the power supply voltage using a "multimeter". This machine's power supply characteristics are indicated on the machine data plate placed on the side of its chassis. For single-phase models, the allowed voltage tolerance is +/- 5% of nominal voltage shown in the machine's data plate; for three-phase models the allowed voltage tolerance is +/- 10%.

If the voltage is over or lower than above mentioned tolerance, the machine's electric components may become damaged.

Pay maximum attention while checking electric component: **danger of electric shocks.**

**1b** Pay maximum attention: **danger of electric shocks.**

Disconnect the machine from the power supply before open the electric box, hence:

- check using a multimeter, the conductivity of the main switch contacts, rotate the switch's knob to position "I" and in case of problems, replace the switch with a new component.

To open the electric box, proceed as following described:



1) Remove the machine cover

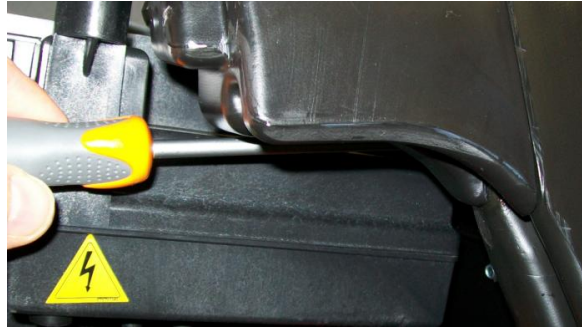

2) unscrew and dismantle the tank inserts

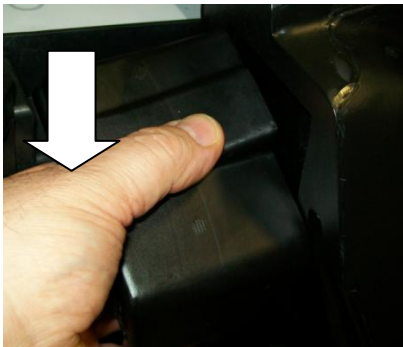

3) slide out the tank inserts

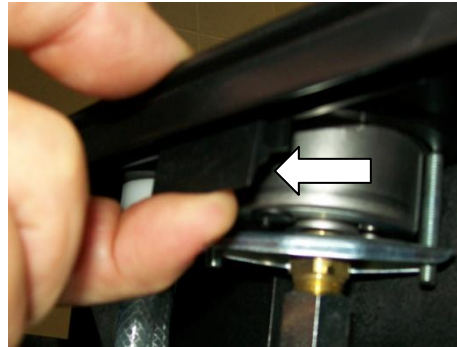

4) unlink the hook that hold electric box panel



5) unlink the side hinges and open the el. box

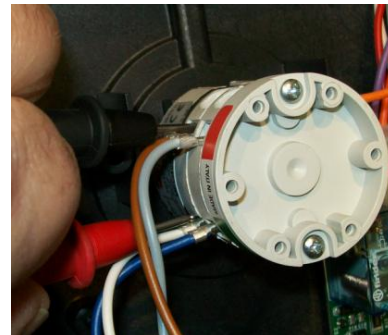

6) check the main switch contacts continuity using a multimeter



7) rotate the switch's knob to position "I" for check

For single-phase models, reset the overload switch pressing its button; for three-phase models, reset the thermal relay.

- If the thermal overload protection intervenes very quickly just after switched on, the cause may be a short circuit problem, hence check connecting the electric components one by one following the electric diagram in order to identify which is defective, then replace it with a new component.

### Single phase version

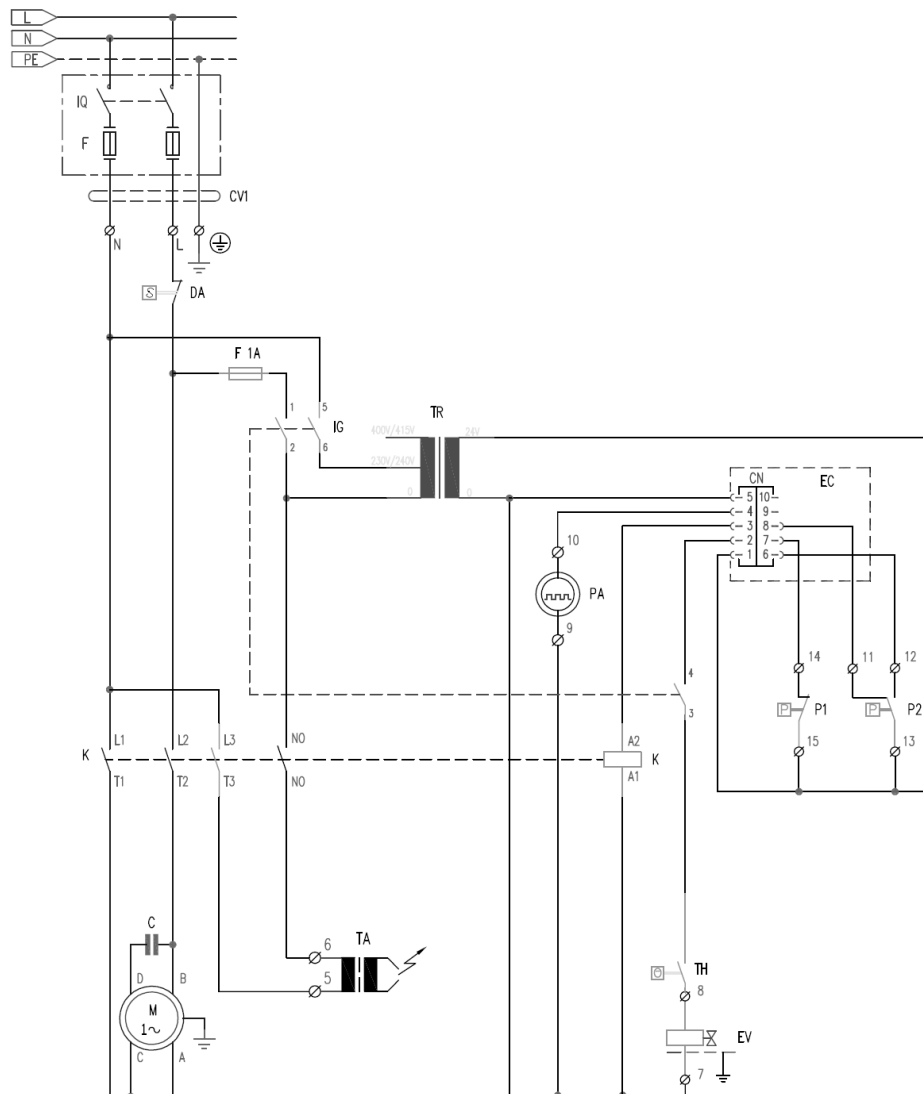

On which:

- IG = Main switch
- DA= Thermal overload switch
- K = Contactor
- C = Electric motor capacitor
- M = Electric motor
- F = Fuse
- TR= Low voltage transformer
- TA = High voltage ignition transformer
- TH = Water temperature adjustable thermostat
- P1 = Pressure-switch N on
- P2 = Pressure-switch N off
- EC = PCboard
- EV = Solenoid of fuel pump
- PA= Antiscale pump

### Three phase version

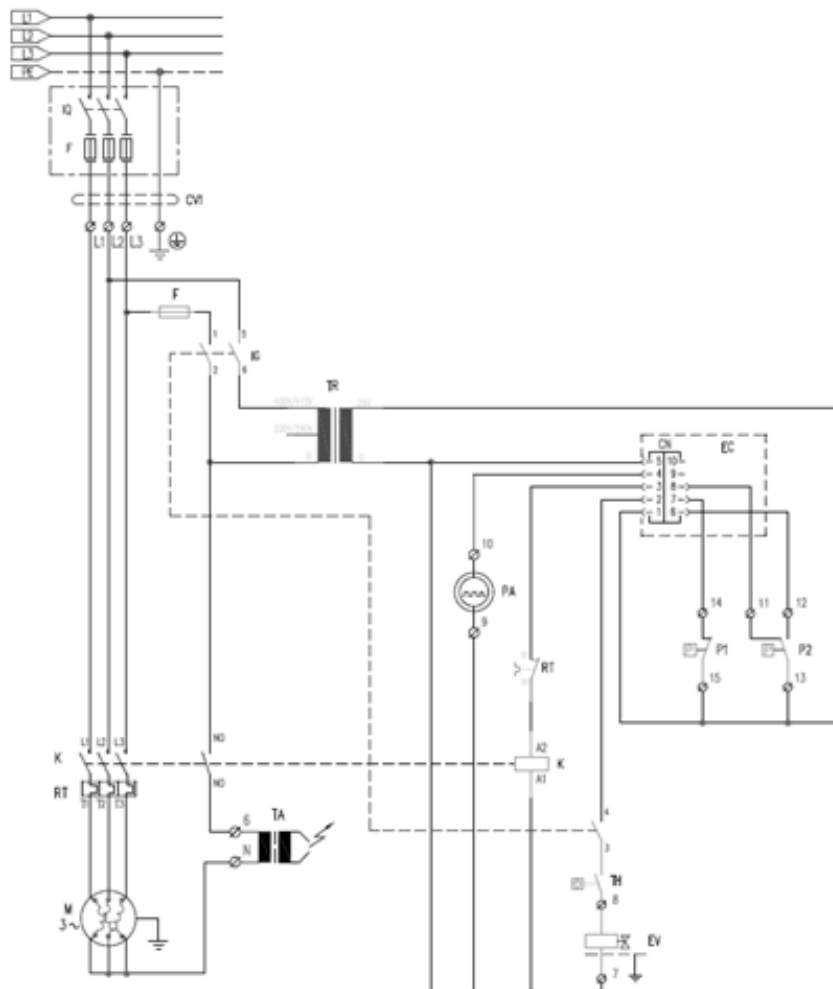

On which:

- IG = Main switch
- K = Contactor
- RT= Thermal relay
- M = Electric motor
- F = Fuse
- TR = Low voltage transformer
- TA = High voltage ignition transformer
- TH = Water temperature adjustable thermostat
- P1 = Pressure-switch N on
- P2 = Pressure-switch N off
- EC = PCboard
- EV = Solenoid of fuel pump
- PA= Antiscale pump



## ELECTRONIC BOARD (p.n.MECE48580)

### Functions description

The electronic board operates machine total-stop; no water system; micro-leakages system; boiler start delay; antiscale pump.

- **Delayed Total stop 15"** (P<sub>1</sub> off ;P<sub>2</sub> off between terminals n° 12-13)  
After 15 "from the end of the grip, the K contactor is de-energized. The machine is in stand-by mode, restarts by opening the grip.
- **Machine without water or water leak from the high pressure circuit (P<sub>1</sub> on ; P<sub>2</sub> off)**  
In this condition activates the count of 3 min and after this the machine stop.  
To restart the machine you must reset the circuit board by opening and closing the main switch IG.
- **Micro-leakages (P<sub>1</sub> ; P<sub>2</sub> on-off impulse <1,5") or lance nozze partially clogged**  
After 10 impulses P<sub>1</sub>, P<sub>2</sub> <1.5 " the contactor K is de-energized. The count is reset with impulse P<sub>2</sub>> 3 ".  
To restart the machine you must reset the circuit board by opening and closing the main switch IG.
- **Delay fuel pump EV**  
The solenoid valve EV is powered with main switch IG in position II (hot water), P<sub>2</sub> on> 3 " and thermostat TH on. The ignition is delayed of 3 "on each impulse of P<sub>2</sub> (OFF - ON).
- **Setting antiscale pump flow**



Min position (-)  $\cong$  4 impulses/min  $\rightarrow$  pump flow  $\cong$  70 ml/h

Max position (+)  $\cong$  16 impulses/min  $\rightarrow$  pump flow  $\cong$  300 ml/h

With machine in t-stop mode the antiscale pump is off.

- In case the overload thermal switch intervenes after a while, is necessary to check the machine Amperage with the machine operating at full load by a Amp clamp meter and compare the measurement done with the characteristics indicated in the machine's data plate. Adjust the thermal relay RT in relation at the machine Amperage measured. The above instruction is valid for three-phase models.



Check the Amperage with a Amp clamp meter

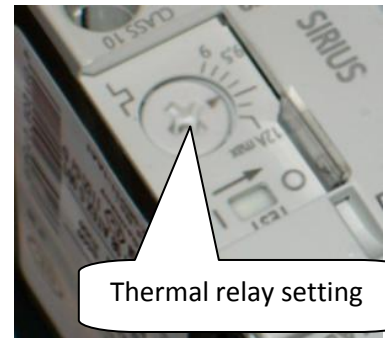

- On single-phase models, reset the overload thermal switch or replace it if defective

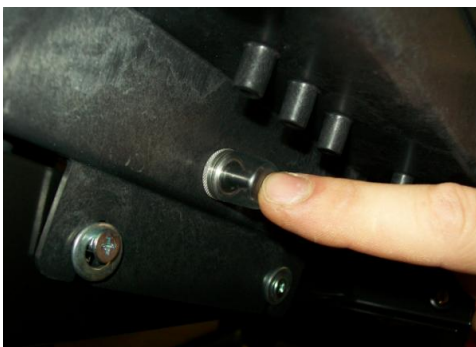

Reset overload thermal switch



O.T.S. internal control box position

**We suggest to do not use extensions to feed the h.p. cleaner.**

In case it is absolutely necessary, make sure that the power plug and socket of the extension cord are the kind watertight; however the connections must be lifted from the ground in order to prevent contact with water.

<p style="text-align: center;"><b>WARNING</b></p> <p style="text-align: center;"><b>USE OF INADEQUATE EXTENSION CORDS MAY CAUSE SAFETY HAZARDS</b></p>	SELECTION TABLE		
	Voltage	Extension cord length	Cord section mm <sup>2</sup>
	230÷240	Up to 20 m	2,5
230÷240	From 20 to 50 m	4	
400÷415	Up to 50 m	2,5	

- Check the continuity of fuses and if burnt, replace them with new fuses having equivalent characteristics.

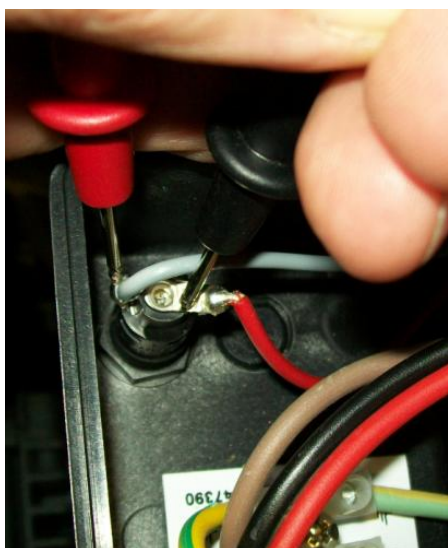

Check the continuity of fuses using a multimeter

We recommend to check the proper functioning of safety electric components, at least once a year.

- **1c** Connect the machine to the power supply, **pay the maximum attention: danger of electric shocks**; hence rotate the main switch to position “I” and check the voltage to the inlet and also to the outlet of the low voltage transformer. In case there is no voltage at the transformer outlet, replace it with a new transformer.

- **1d** Check the voltage to the contactor’s coil and the continuity to the contactor’s contacts. If there is no voltage to the contactor’s coil, also when the main switch is at position “I”, neither pressure to the machine’s outlet circuit, check also the pressure-switches and particularly P2 should be N.O. (normally open) and P1 should be N.C. (normally closed).

Here following the functioning diagram for this machine model:

## 1. Starting phase

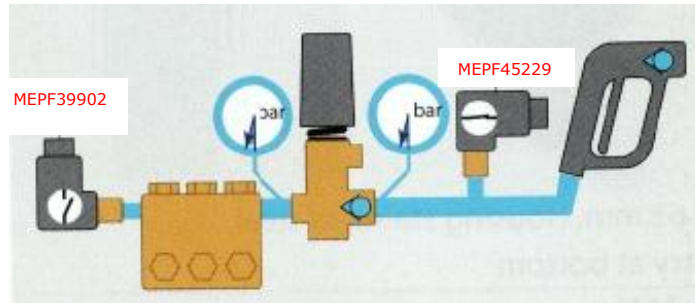

The contact of pressure switch (P1) MEPF45229 is ON (closed); in this situation, when the main switch is turned to “I” position, the machine starts.

## 2. High pressure phase

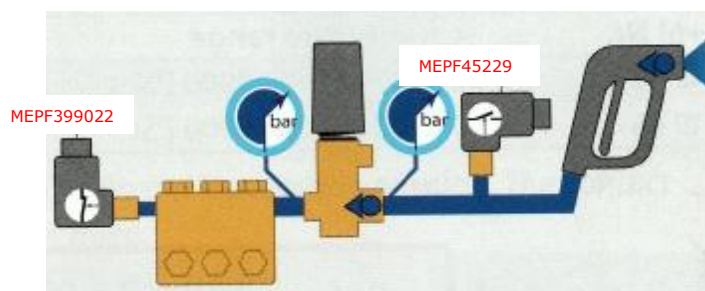

When pressure becomes over 25 bar, the pressure switch (P2) MEPF39902 switches from open (OFF) to closed (ON), this allow the machine functioning and in the meantime the pressure switch (P1) MEPF45229 switches from closed (ON) to open (OFF).

## 3. Stopping phase

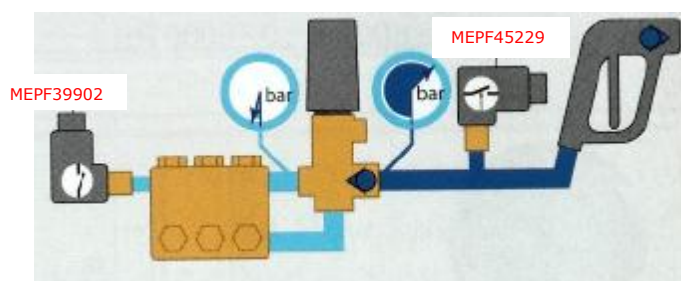

When the spray gun's trigger is released, the water flow is by-passed with no pressure, into the high pressure pump by the by-pass valve; hence the pressure-switch (P2) MEPF39902 switches from closed (ON) to open (OFF); the machine stops, because also the pressure-switch (P1)

MEPF45229 is open (OFF). The machine's outlet hydraulic circuit, is kept under pressure by the spray gun and the check valve placed at the by-pass outlet. The machine is now in "stand-by", until the spray gun's trigger is reactivated in order to discharge the outlet pressure and restart from the phase "1" (starting phase).

In case that all the above mentioned check doesn't evidences any functioning mistake, the failure is probably caused by the electronic control board "EC". Check and if necessary replace it with a new electronic board.

## • 2. No water jet at the lance nozzle

2) **TROUBLE:** No water jet sprayed from the lance nozzle.

- CAUSES:**
- 2a** Bad or missing water feeding connection
  - 2b** Inlet water filter clogged
  - 2c** Air intake from the water feeding circuit
  - 2d** Pump head's valves stuck
  - 2e** Air intake from the detergent circuit
  - 2f** High pressure nozzle clogged

**REMEDIES:**

**2a** Check the feeding water flow (l/min), in order to ensure that feeding water available is sufficiently high compared with the machine characteristics.

The feeding water flow (l/min) must exceed at least 10%, than the water flow characteristics declared in the machine data plate.

Check the fittings to the water inlet circuit and particularly ensure they are not damaged or not properly sealed, causing flow obstruction or air intakes.

**2b** Check and clean the water inlet filters and if necessary, replace them.

**NOTE** Do not use tools for remove the h.p. pump inlet filter



Check the filter at the inlet fitting

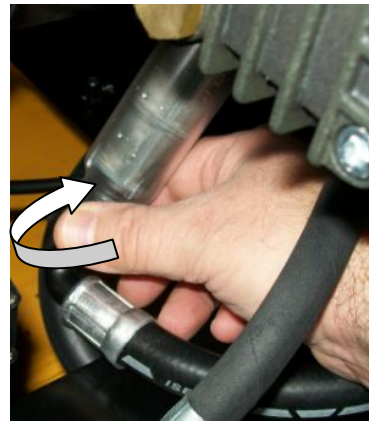

Check the filter at the h.p. pump inlet



Check the filter cartridge

We recommend to check the water filters every 50 hours (or every week)



**2c** Check the water circuit that connects the water tank to the high pressure pump inlet, particularly check that fittings are properly tightened and are not leaking water.

Be sure that the detergent tap is closed, if detergent tank is empty.

In order to put in evidence any area not sealed, that intakes air, we suggest to feed directly with pressurized water the pump inlet fitting.

The pressure of the feeding water, will put in evidence any area not properly sealed by leaking water; in the case proceed with their repair.

**2d** Check the inlet and outlet valves placed into the pump head; if the valves are stuck, unstuck the valve from its seat manually pressing gently the valve disk until released.

If the valves are dirty, disassemble them and clean.

In order to check and repair the high pressure pump, is necessary to dismantle the machine handle as following describe:



Unscrew the tank lock nut



Remove the screws cover



Remove the lock screws



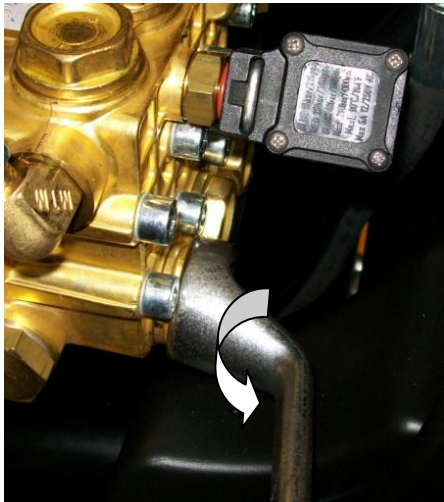

Unscrew the inlet valve caps



Unscrew the outlet valve caps



Strip out the valves

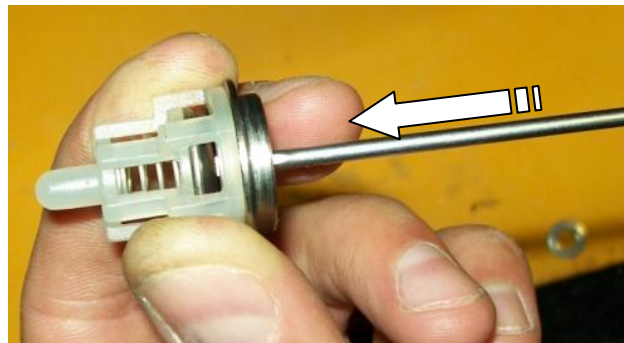

Clean and unstuck the valves

We recommend the replacement of inlet and outlet valves every 500 hours or one a year.



**2e** Check the detergent knob adjust (pic.1 C); it must be placed in position “closed”.

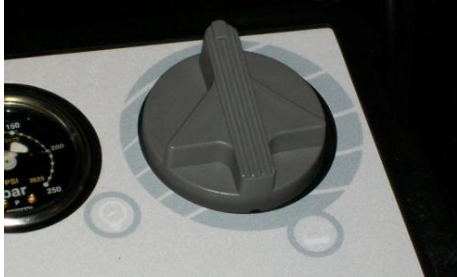

**Close position**



**Open position**

Check the o-ring wear that is placed inside of the detergent tap, remove the detergent tap from the control panel as following:

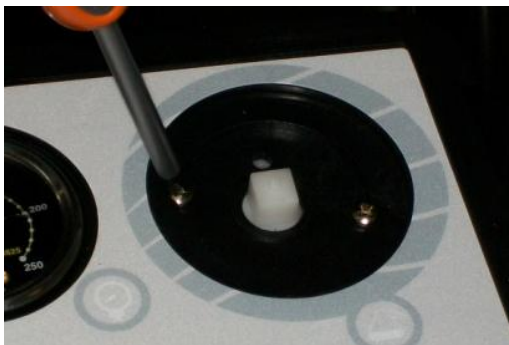

**Unscrew the two screws that hold the tap**



**Detergent tap with its spring and washer**



**O-ring of detergent tap in detail**

Check the whole detergent circuit in order to ensure that there are no holes or cuts to the rubber pipes; check the proper tightening of the metal bands.  
Finally check the detergent check valve (VNR) that is placed after the water inlet filter (to be checked the wear of o-ring, spring and ball of VNR).

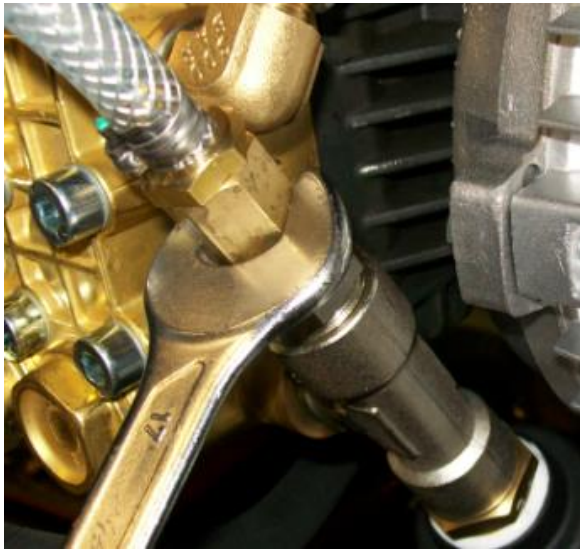

Disassembling of VNR

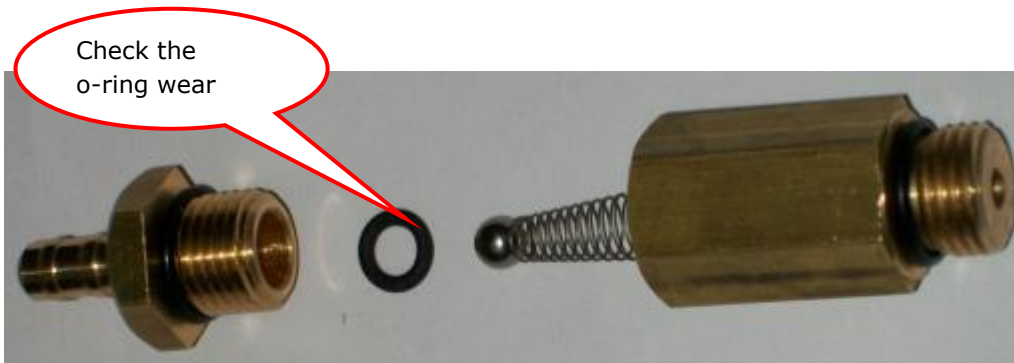

Check the o-ring wear and clean the VNR internal body

**2f** Clean the high pressure nozzle and if necessary, replace it with a new genuine part. Check the spare part manual that is downloadable from the web from "Business area" of [www.ipcleaning.com](http://www.ipcleaning.com) ; to access this area, customers registration is required.



Clean or replace the h.p. nozzle

We recommend the high pressure nozzle replacement every 200 hours or any time the machine working pressure become 20% lower than rated pressure.

### 3. No pressure to the lance

3) **TROUBLE:** The high pressure pump rotates, but doesn't achieve the rated pressure or the pressure is not stable and fluctuates.

- CAUSES:**
- 3a** Defective water feeding connection
  - 3b** Inlet water filter clogged
  - 3c** Air intake from the water feeding circuit
  - 3d** Pump head's valves stuck or worn
  - 3e** Air intake from the detergent circuit
  - 3f** High pressure nozzle worn or deformed
  - 3g** Pressure adjusting valve setting at minimum position
  - 3h** Seat of pressure adjusting valve damaged
  - 3i** Pump gaskets worn or water leaks from the pump's head

**REMEDIES:**

**3a** Check the feeding water flow (l/min), in order to ensure that feeding water available is sufficiently high compared with the machine characteristics.

The feeding water flow (l/min) must exceed at least 10%, than the water flow characteristics declared in the machine data plate.

Check the fittings to the water inlet circuit and particularly ensure they are not damaged or not properly sealed, causing flow obstruction or air intakes.

**3b** Check and clean the water inlet filters and if necessary, replace them. See **2b**

We recommend to check the water filter every 50 hours (or every week)

**3c** Check the water circuit that connects the water tank to the high pressure pump inlet, particularly check that fittings are properly tightened and are not leaking water.

Be sure that the detergent tap is closed, if detergent tank is empty.

In order to put in evidence any area not sealed, that intakes air, we suggest to feed directly with pressurized water the pump inlet fitting.

The pressure of the feeding water, will put in evidence any area not properly sealed by leaking water; in the case proceed with their repair.

**3d** Check the inlet and outlet valves placed into the pump head; if the valves are stuck, unstuck the valve from its seat manually pressing gently the valve disk until released (see **2d**).

If the valves are dirty, disassemble them and clean.

If the valves are worn or deformed, replace them and also replace the o-ring placed under the valves.

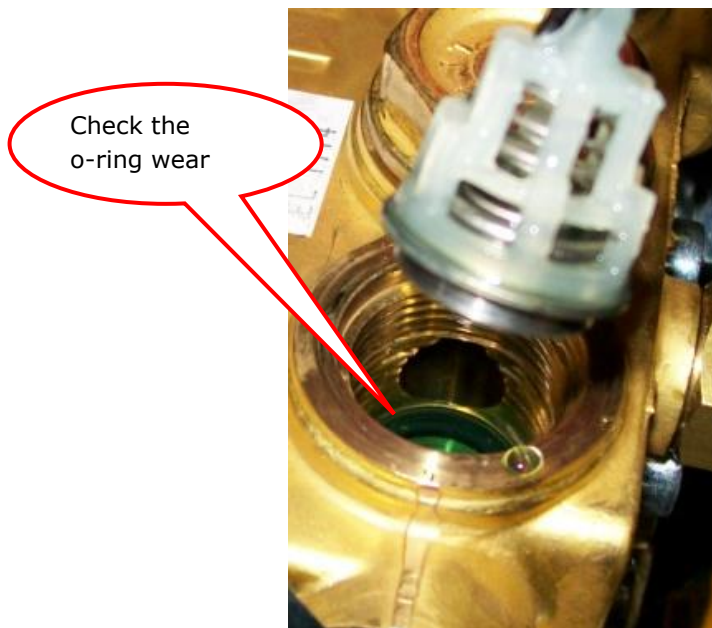

We recommend the replacement of inlet and outlet valves every 500 hours or one a year.

**3e** Check the detergent knob adjust (pic.1 C); it must be placed in position “closed”.  
Make checks as described in the paragraph **2e**

**3f** Replace the high pressure nozzle with a new genuine part.  
Check the spare part manual that is downloadable from the web from “Business area” of [www.ipcleaning.com](http://www.ipcleaning.com) ; to access this area, customers registration is required.

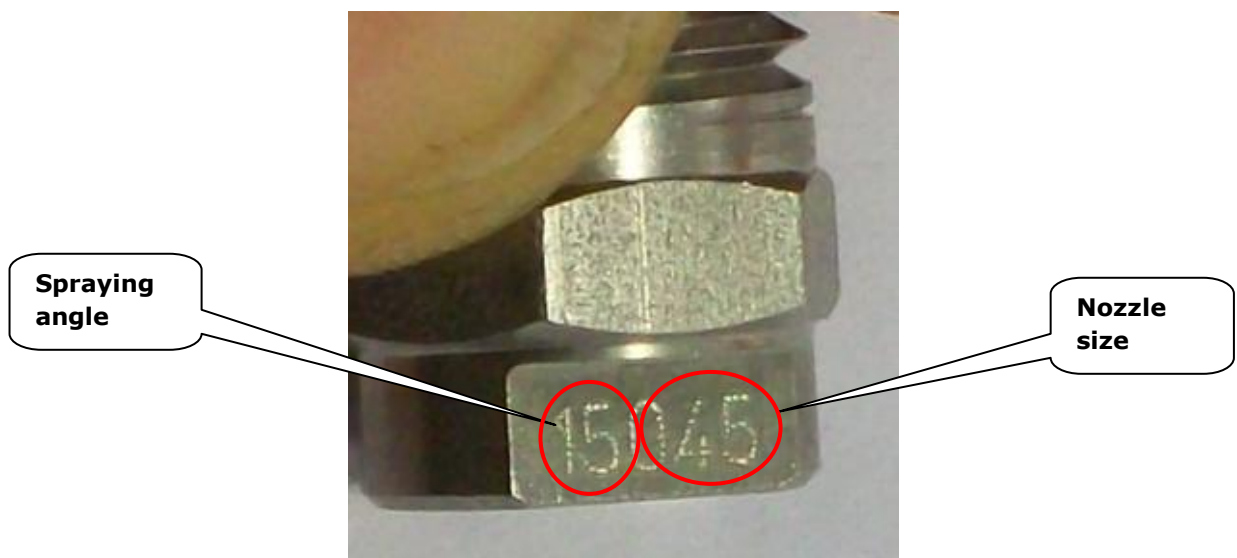

We recommend the high pressure nozzle replacement every 200 hours or any time the machine working pressure become 20% lower than rated pressure.



**3g** Check if the pressure adjusting knob is set to maximum position.  
The position maximum is when the knob is fully rotated clockwise.



**3h** Repair the pressure adjusting valve (by pass valve) by replacing its cartridge that is part of the dedicated repairing kit.



Strip out the knob



Remove the valve guide





Unlock the valve kit

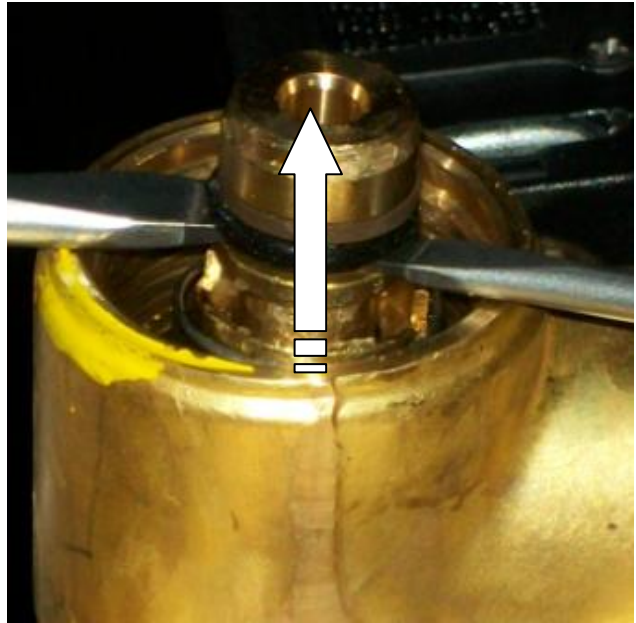

Use two screwdrivers as shown in the picture



Remove the valve kit



Remove the by-pass seat, use a M6 screw

**After replaced the valve kit, will be necessary to readjust the machine working pressure.**

The pressure adjustment can be done trough the adjusting screw as indicated in the following picture:

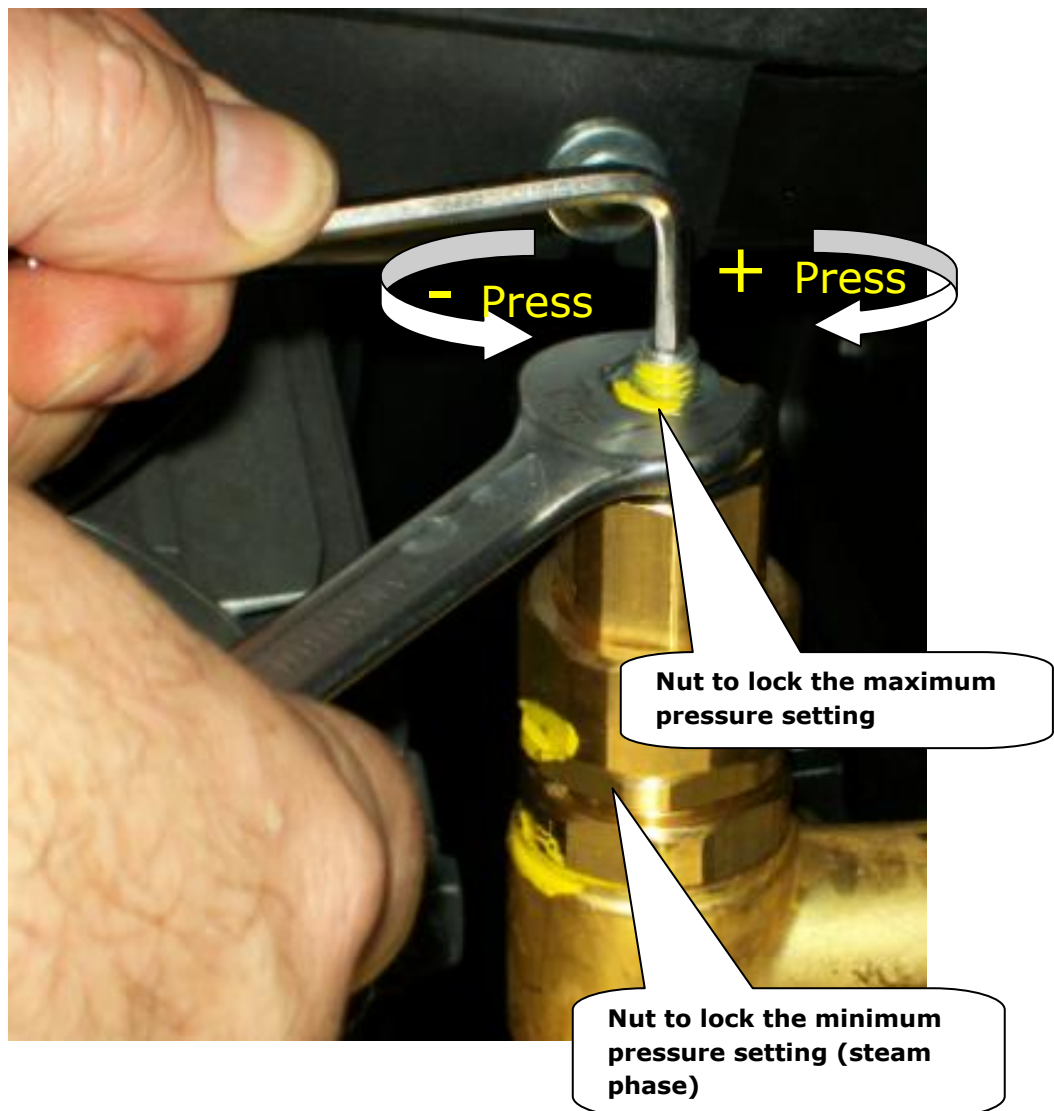

In order to readjust the machine pressure setting, the lance high pressure nozzle must be brand new, for setting values, check the pressure characteristics indicated in the machine data plate.





**3i** Replace the high pressure pump's gaskets kit and ensure that the ceramic pistons are not damaged. If ceramic piston are cracked, replace them following the instruction as described in the paragraph 8c.



Remove the pressure switches



Disconnect all the hoses fitted to the pump head



Disconnect the pump inlet fitting



Unscrew the 8 screws that hold the pump head



Remove the pump head

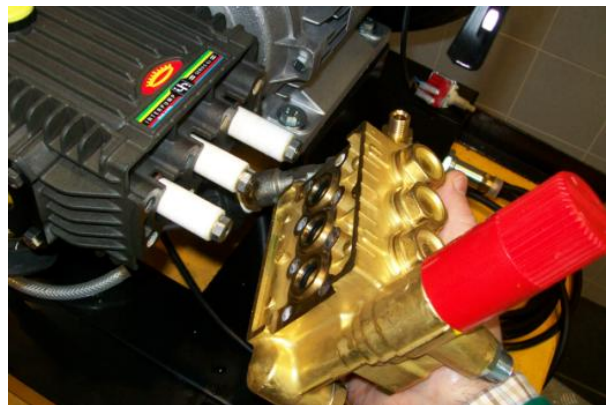



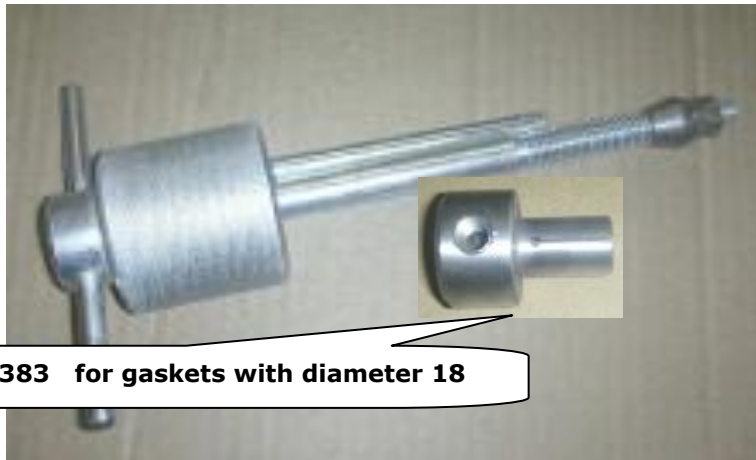

**Head p/n PVVR31383 for gaskets with diameter 18**

**Strip out the pump gasket packages using the extractor tool p/n PVVR31382**

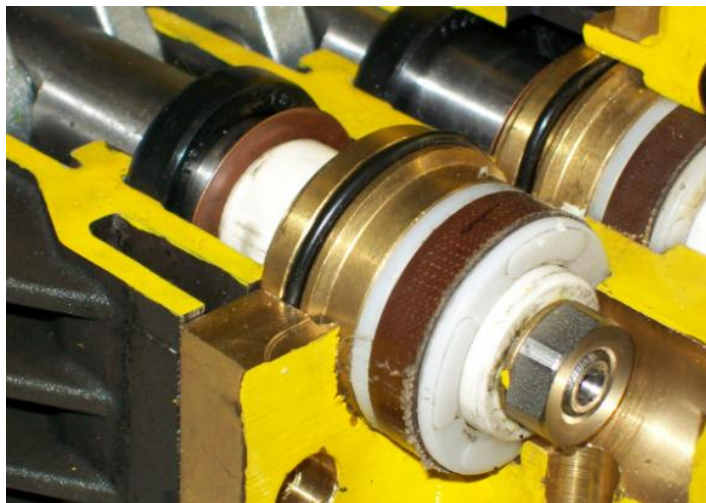

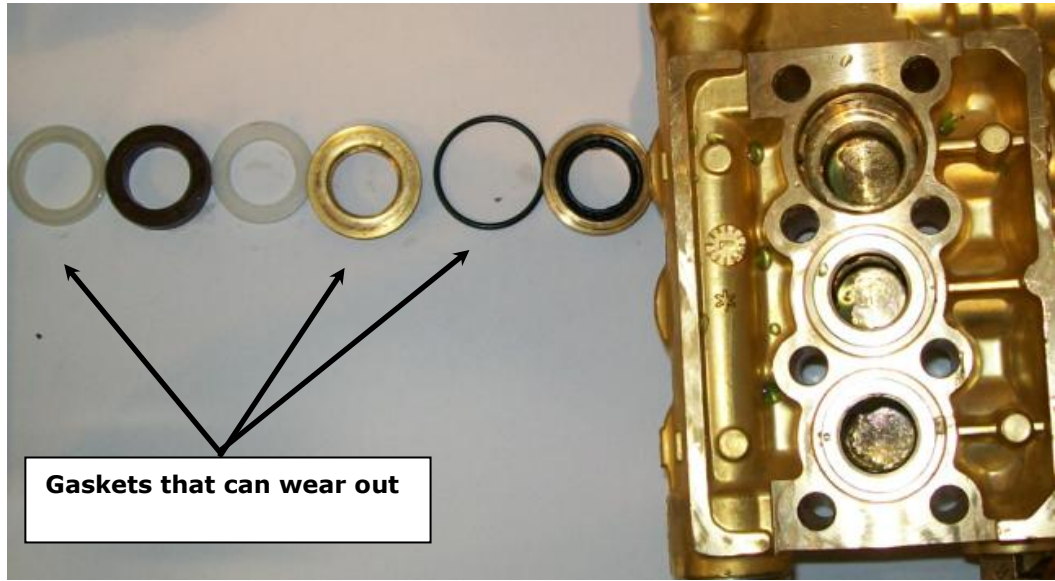

## 4. The boiler doesn't ignite

4) **TROUBLE:** Switching on the burner by setting the thermostat at the desired temperature, but the burner doesn't ignite.

- CAUSES:**
- 4a** Wrong blower's motor rotation sense (only for Triphase models)
  - 4b** Missing fuel
  - 4c** Suction pipe and/or fuel filters clogged
  - 4d** Fuel pump out of order
  - 4e** Fuel solenoid not electrically supplied or defective or damaged
  - 4f** Fuel nozzle clogged or spraying irregularly
  - 4g** High voltage ignition transformer not functioning
  - 4h** Sparking plugs are dirt or worn

### REMEDIES:

**4a** Only on three-phase models: check the correct rotation sense of the electric motor (if rotation is correct, air flow must be discharged from the boiler chimney).

If rotation sense is not correct, no air flow is discharged from the chimney, hence switch two phases on the three-phase plug to reverse the motor rotation sense.

**4b** Check the fuel level inside of the fuel tank, if tank is empty, refill the tank with fuel till max. level.

**4c** Check if fuel flows into the fuel circuit, check and remove any possible obstruction to the suction pipe, if necessary replace the suction fitting.



Check the fuel cartridge filter, if clogged replace it.

Check and clean the fuel filter inside of the fuel pump. If necessary replace it.



We recommend to check the fuel filter every 100 ore

**4d** Check with a pressure gauge (p/n **AZMC27323**) the fuel pump's setting pressure that should be in the interval 12,5 - 13bar.



**Pressure gauge plug**

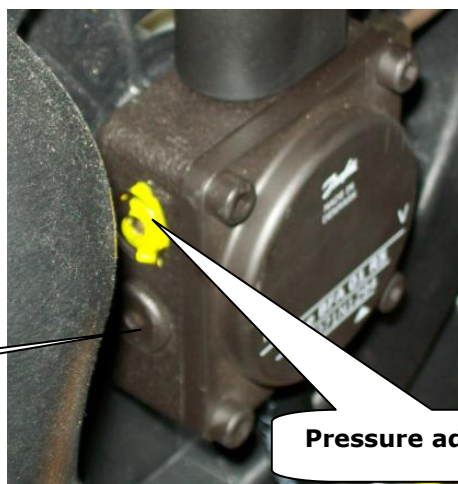

**Pressure adjust screw**



If fuel pump doesn't develops any pressure, check the plastic joint placed between the pump and the motor shaft that transmits the rotation to the pump, probably is damaged.

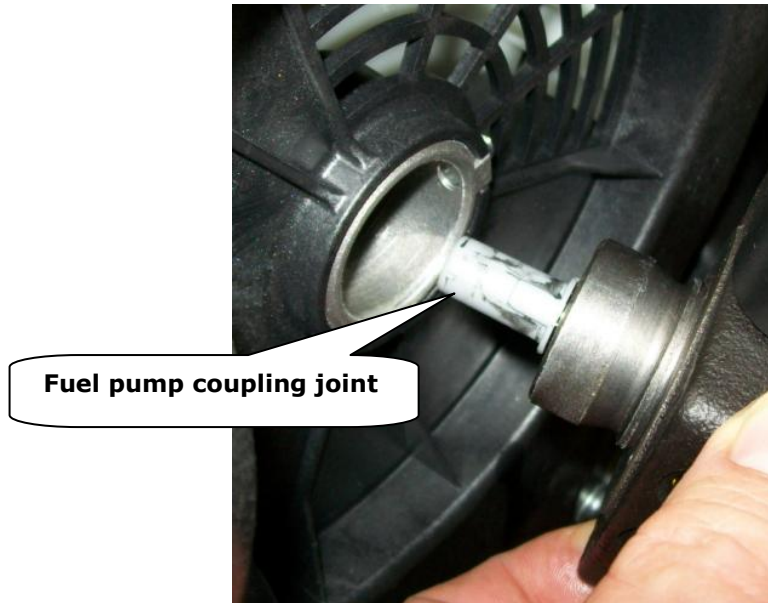

If the plastic joint is worn or damaged, replace it; check the free rotation of the fuel pump shaft by rotating it manually, finally check and eliminate any air intake problem from whole the fuel circuit.

Clean the filter placed inside of the fuel pump.

If after all the above mentioned checks, still missing the pressure to the fuel circuit, replace the complete fuel pump, hence adjust its operating pressure.

We recommend to clean the fuel tank by opening the tank's drain caps and the fuel replacement.



We recommend to check and clean the fuel pump and the fuel tank every 200 hours.



**4e** Check the voltage to the fuel solenoid using a multimeter, the voltage to EV, should be (230V+/- 5%), then check:

- Check the proper functioning of the pressure-switch P1 placed to the high pressure pump head. Check if the pressure-switch piston slides regularly (switch should be ON when under pressure and OFF during by-pass phase), then check if the switch inside of the pressure-switch functions correctly. If not working properly replace the whole pressure-switch.
- Check the functioning of the N.O. contact of the thermostat. If the contact is opened despite the thermostat activation, replace the thermostat with a new one.
- If both the pressure-switch and the thermostat are functioning properly, replace the control board TM.

If all the above mentioned component are functioning properly, replace the fuel solenoid "EV".

**4f** Replace the burner nozzle with a brand new nozzle:

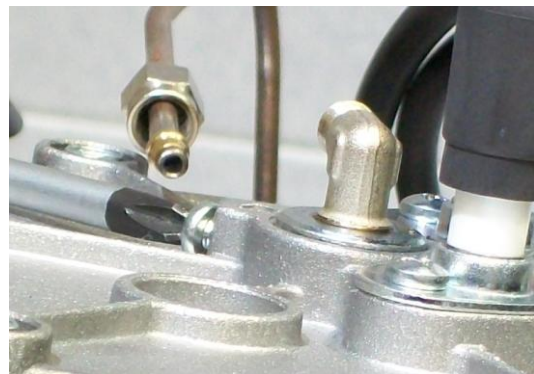



**Note** : While replacing the burner nozzle, do not touch the nozzle orifice with fingers to avoid its oxidation hence modify its characteristics.

We recommend to replace the burner nozzle every 200 hours.

**4g** Check the power supply voltage to the high voltage ignition transformer: it should be 230V (+/- 5%) on single-phase models and 400V (+/- 10%) on three-phase models.

If the voltage is lower than the above mentioned, check the voltage at the main power supply line and in case there is no voltage, check the following:

- proper electrical connection and tightening, of the high voltage transformer's power wires, connected to connection board in the electric box.
- proper functioning of the aux contact of the contactor (see the electric diagram placed inside of the machine's electric box, or the electric diagram at the chapter **1b**)
- proper functioning of the noise reduction filter LC (only for single-phase models).

If the voltage to the high voltage transformer is correct, check the high voltage wires AT, that are connected to the transformer outlet and particularly check if they are properly plugged in to the transformer and to the electrodes.

Check that AT wires are not damaged or cracked, if necessary replace them.

Strip out the whole combustion head and check if electrodes make a spark arch (electrodes must be clean and adjusted at proper distance each other); if there is no spark between the electrodes, replace the High Voltage Transformer.

**4h** Strip out the whole combustion head and check if electrodes make a spark arch between their top edges. If there is no spark between the electrodes, check the High Voltage Transformer functioning as described in the chapter **4g**, clean the electrodes and check they are not damaged or cracked, check and if necessary, adjust the gap between the electrodes:

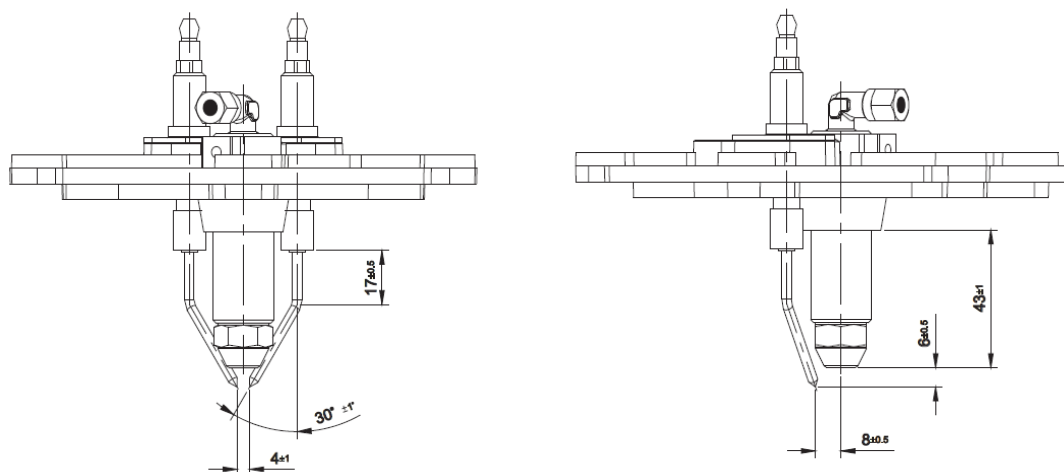

If the ceramic insulation of the electrodes is cracked, replace them and check also the gap between the electrodes as per above scheme.

We recommend to check and adjust the electrode position every 200 hours and replace them every 500 hours.

## 5. Bad fuel combustion

5) **TROUBLE:** Excessive smoke from the chimney

- CAUSES:**
- 5a** Fuel tank almost empty
  - 5b** Suction pipe and/or, fuel filters clogged
  - 5c** Fuel pump pressure setting not properly adjusted
  - 5d** Fuel with impurities, dirt or water
  - 5e** Combustion adjustment incorrect
  - 5f** Burner's coil clogged by dirt or soot
  - 5g** Fuel nozzle partially clogged

**REMEDIES:**

**5a** Check the fuel quantity inside of the fuel tank, if necessary refill the tank with fuel up to max. level.

**5b** Check and clean as indicated in the chapter **4c**

**5c** Check by using the pressure gauge (p/n **AZMC27323**), the Fuel Pump pressure that should be adjusted between 12,5 and 13 bar max., if necessary proceed as described in the chapter **4d**.

**5d** Drain out the fuel from the fuel tank by opening the drain caps, clean carefully the fuel tank, clean or replace if necessary the fuel filters as described in the chapter **4c**

**5e** Check and adjust the combustion, using the smoke tester tool (p/n **AZMC20915**); The combustion test, is performed comparing the smoke color and the smoke color scale, belonging to Bacharach Shell scale.

The color of the smoke should be between points 0 and 2 of the Bacharach scale.





In order to check the combustion accordingly to Bacharach Shell method, proceed as following described:

- Switch on the machine and also the machine's boiler, fit to the tester the paper filter (C) and use the smoke pump (A) in order to make 10 pump actions, hence obtain a gray colored spot, to the filter paper.

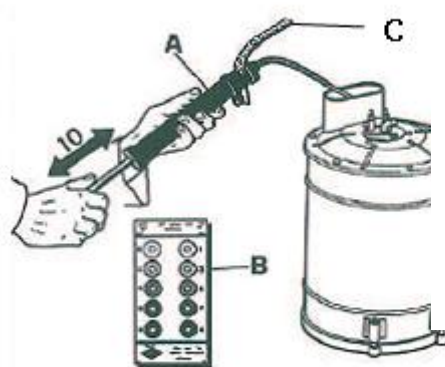

- If the grey color spot will be more dark, than the point "2" of the Bacharach Shell scale (B), increase the air flow to the boiler by adjusting the blower and finally repeat the smoke test as before explained.

- If the spot looks a little yellow colored, the air flow at the boiler is too much and should be reduced. Reduce the air flow at the boiler from the blower and repeat the smoke test as before explained.

In order to achieve the best combustion and proper adjustment, we recommend to use clean and good quality fuel (Cetane, should be not less than 52)

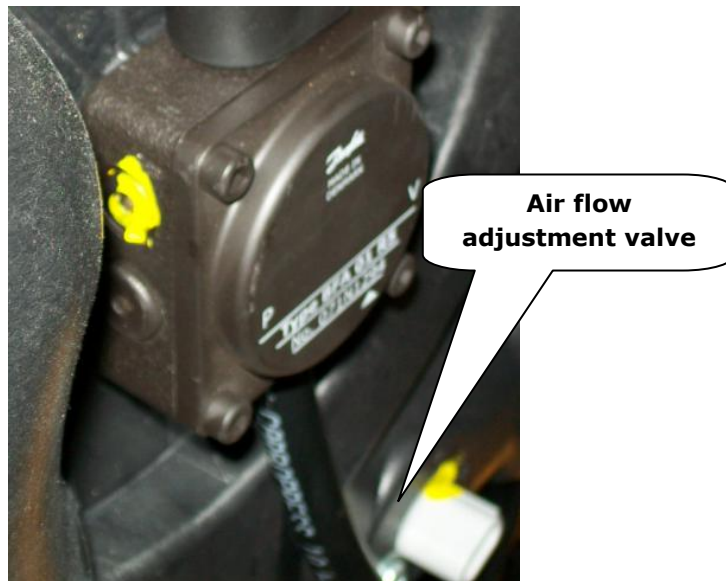

The combustion setting should be done with the thermostat adjusted at maximum temperature; before starting the smoke test, let the boiler functioning continually for 1 minute at least.

**5f** Disassembling of the boiler and cleaning of the boiler's coil:



Disconnect all electric cable and pipes, dismantle the boiler supports.

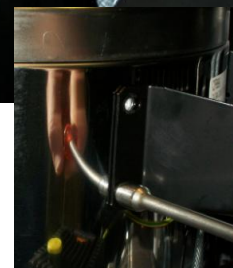

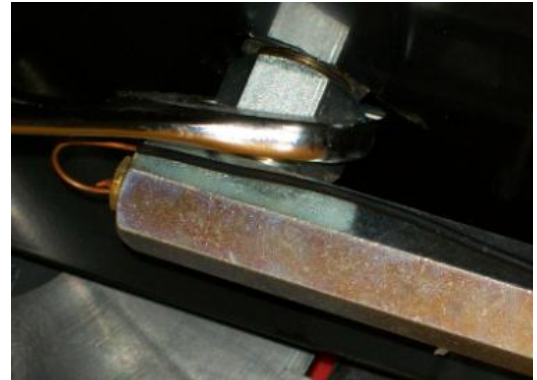

Unscrew the nuts that fix the tanks and remove the tanks, disconnect the inlet and outlet fittings from the boiler.



Strip out completely the boiler from the machine (to slide and rotate the boiler in order to disconnect it from the blower), then proceed with the cleaning of the coil that can be done with the help of a metal brush and a vacuum cleaner to remove the soot. The coil cleaning, can be done also by washing the part with high pressure and in combination with proper detergents.

**5g** Replace the burner nozzle and check the gap between the electrodes as indicated into the drawing at the paragraph **4h**

## 6. Poor hot water at the machine outlet

6) **TROUBLE:** The water is not warm enough

- CAUSES:**
- 6a** Thermostat adjusted at minimum or not working
  - 6b** Fuel filters clogged or dirty
  - 6c** Fuel pump pressure setting not properly adjusted
  - 6d** Fuel with impurities, dirt or water
  - 6e** Fuel nozzle partially clogged
  - 6f** Burner's coil pipe internally clogged by limestone

### **REMEDIES:**

**6a** Set the thermostat at maximum position and switch on the machine, if the boiler doesn't work, means that the thermostat is broken. Replace the thermostat, but ensure that there is no pressure at the machine outlet circuit before dismantling the thermostat probe; discharge the pressure with the machine switched off, release the pressure by triggering the spray gun trigger.

**6b** Check and clean as described in the chapter **4c**

**6c** Check and clean as described in the chapter **4d**

**6d** Check and clean as described in the chapter **5d**

**6e** Check and clean as described in the chapter **5g**

**6f** Clean internally the coil's pipe, in order to remove the limestone, using the chemical product M402 (see the IPC Portotecnica catalogue). **Warning:** M402 is an acid chemical, wear the individual protection devices to prevent accidents and injuries.

Follow the instruction written on M402's product label, in order to prepare the acid solution; to make circulating the acid into the coil and remove the limestone, use the pumping tool designed for this operation.

When limestone removal operation with acid, has been completed, repeat the operation by using an alkaline chemical, in order to neutralize the acid effects that may slowly corrode the pipe (i.e. using the chemical type U102).

**WARNING!!** Follow the rules in force for chemicals waste, DO NOT waste in the environment.

## 7. Poor detergent delivery

7) **TROUBLE:** Poor detergent delivery

- CAUSES:**
- 7a** Detergent's tap closed or clogged
  - 7b** Empty detergent tank
  - 7c** The check valve of the detergent circuit is stuck or clogged
  - 7d** Burner's coil or high pressure outlet pipes clogged

### **REMEDIES:**

**7a** Open the detergent tap, dismount the tap and clean the internal side, check and remove the dirt if clogged. See instructions at chapter **2e**.

**7b** Refill with detergent the chemical tank if it is empty; we recommend to use only the detergents listed in the IPC Portotecnica catalogue.

**7c** Dismount and clean the detergent check valve as described in the chapter **2e**.

**7d** Clean the detergent circuit's hoses, replace them if are damaged, clean the coil as describe in the chapter **6f**

## 8. Oil and water emulsion phenomena to the high pressure pump oil

**8) TROUBLE:** The oil inside the high pressure pump looks white color (oil and water emulsion phenomena)

- CAUSES:**
- 8a** Extremely high environment humidity percentage
  - 8b** High pressure pump gaskets worn
  - 8c** High pressure pump pistons damaged

### REMEDIES:

**8a** Replace the pump's oil using oil quality SAE 15 /W40:

Unscrew the cap "C" in order to drain the oil from the high pressure pump; wait until the oil being totally drained out to the recovery tank.

Oil, must be wasted in compliance with the country rules in force for oils. Screw the cap "C" and refill the oil into the pump from the port "B", the oil level is detectable from the oil window "A".

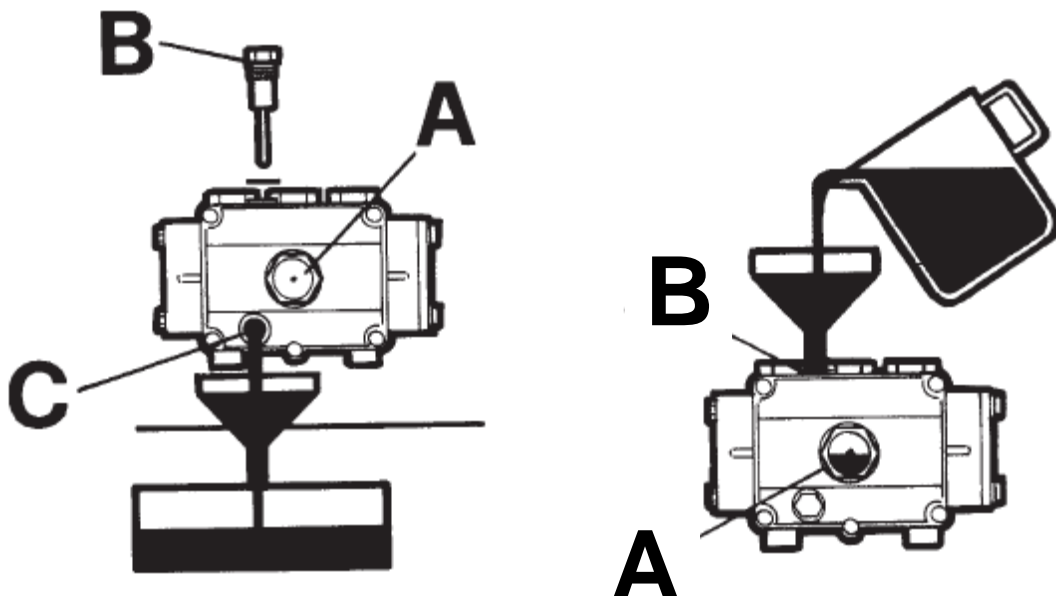

We recommend a proper ventilation of the place where the machine operates, in order to reduce as much as possible the environment humidity percentage.

**8b** Replace the pump's water gaskets as described in the chapter **3i**



**8c** Replacement of the pump's pistons:

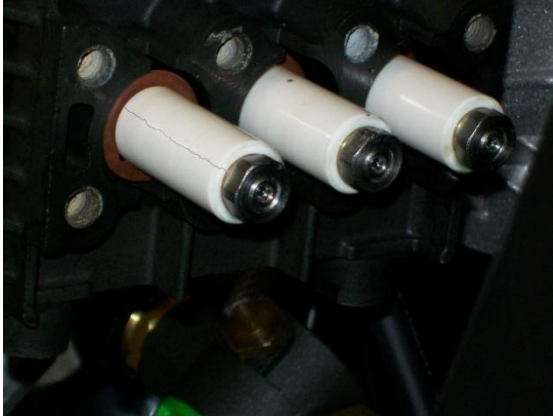

Check if pistons are cracked

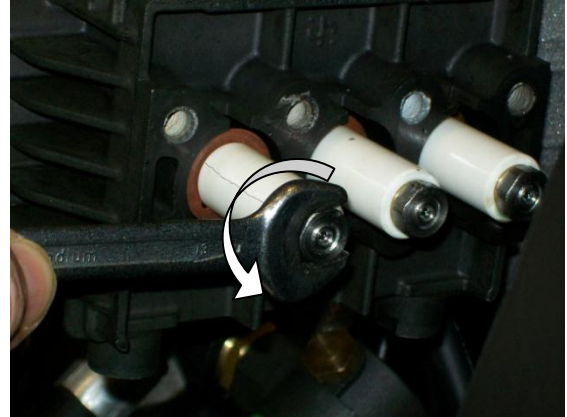

Unscrew the piston lock nut

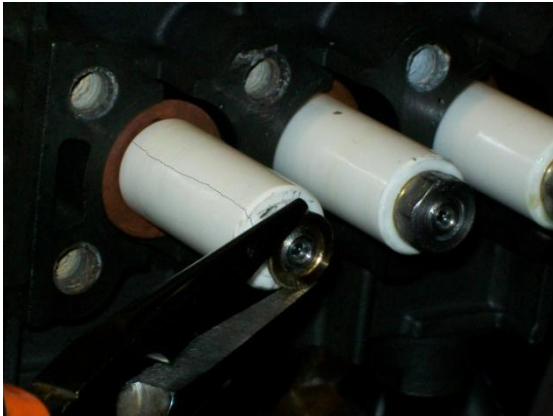

Slide out the piston bush



Slide out the damaged piston

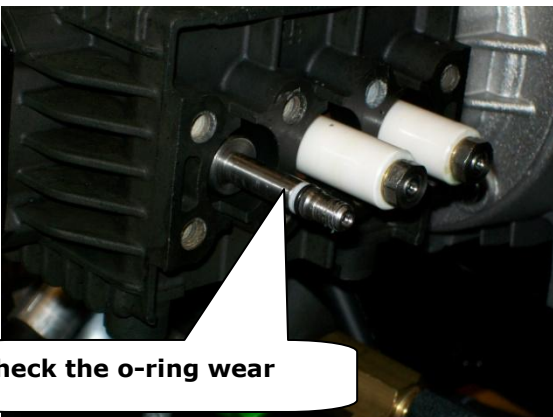

Check the o-ring wear

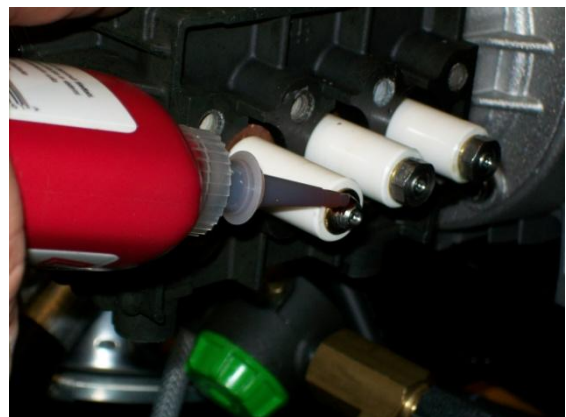

Assemble the new piston and secure the nut with "Loctite" glue.

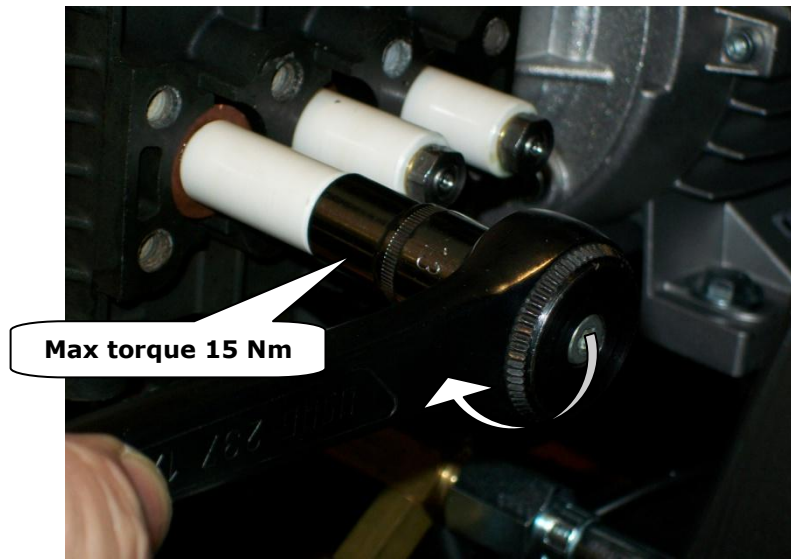

Tighten the nut at max torque 15 Nm.



## Periodic maintenance

	Every day	Every 50h	Every 100h	Every 200h	Every 300h	Every 500h	Every year		
Check the power cord and the high pressure quick couplings.	◆								
F i r s t p u m p o i l r e p l a c e m e n t		◆							
P u m p o i l r e p l a c e m e n t						◆			
F u e l f i l t e r s c l e a n i n g a n d r e p l a c e m e n t			◆						
F u e l t a n k c l e a n i n g			◆						
W a t e r f e e d i n g f i l t e r s c l e a n i n g		◆							
B o i l e r a n d c o i l c l e a n i n g f r o m s o o t				◆					
B o i l e r c o i l l i m e s t o n e c l e a n i n g					◆				
F u e l p u m p f i l t e r c l e a n i n g				◆					
B u r n e r n o z z l e r e p l a c e m e n t				◆					
S p a r k i n g e l e c t r o d e s g a p a d j u s t m e n t				◆					
S p a r k i n g e l e c t r o d e s r e p l a c e m e n t						◆			
P u m p ' s w a t e r g a s k e t s r e p l a c e m e n t						◆			
H i g h p r e s s u r e n o z z l e r e p l a c e m e n t				◆					
C h e c k a n d a d j u s t o f t h e s a f e t y d e v i c e s o r c o m p o n e n t s							◆		